

PC21 Test Board for the A111 and A111F

The PC21 is a printed circuit board designed to facilitate testing of the A111 or the A111F. In addition to testing circuitry, it provides component locations for use with detectors. Ground plane construction minimizes external pick-up.

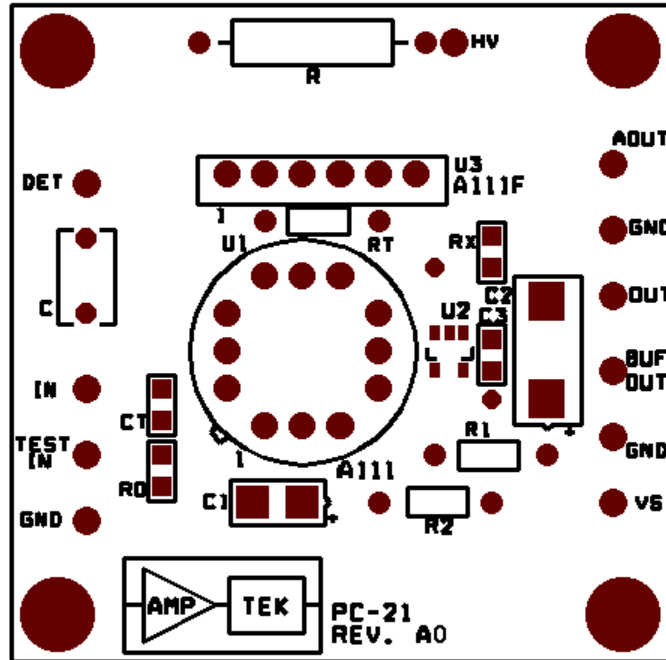

Dimensions: 1.75 in. square (4.45 cm square)

INPUTS

- IN: Detector input; A111/PIN 12; A111F/PIN 1. Should be AC coupled with a high voltage capacitor (500 pF - 1000 pF).
- DET: Provides post to connect the detector and input capacitor.
- TEST IN: Input to test circuit as described in specifications.
- V_S: A111/PIN 2; A111F/PIN 5; supply voltage (+4 to +10 VDC).
- H.V.: Provides post to connect the detector to the high voltage supply through a resistor.

OUTPUTS

- OUT: Positive, TTL type output from A111/PIN 5; A111F/PIN 6.
- A OUT: Positive, Analog output from A111/PIN 7; A111F/PIN 4.
- BUF OUT: Positive output through a Buffer/Line Drive IC from A111/PIN 5; A111F/PIN 6.

COMPONENTS

- C₁, C₂, C₃: Filter capacitor (1 uF, 4.7 uF, 0.1 uF).
- C_T: Test capacitor (2 pF).
- R_O: Test pulse termination (50 ohm).
- R_X: External load resistor (see specifications).
- R_T: Threshold adjustment resistor.
- R: Detector bias resistor (user supplied).
- C: Detector coupling capacitor (H.V.) (user supplied).
- U₂: Line Driver TPS2829.

Amptek Inc. 14 DeAngelo Drive, Bedford, MA 01730-2204 USA

Tel: +1 781 275-2242 Fax: +1 781 275-3470 Email: sales@amptek.com <http://www.amptek.com>

PC21 Wiring Diagram for the A111 or A111F

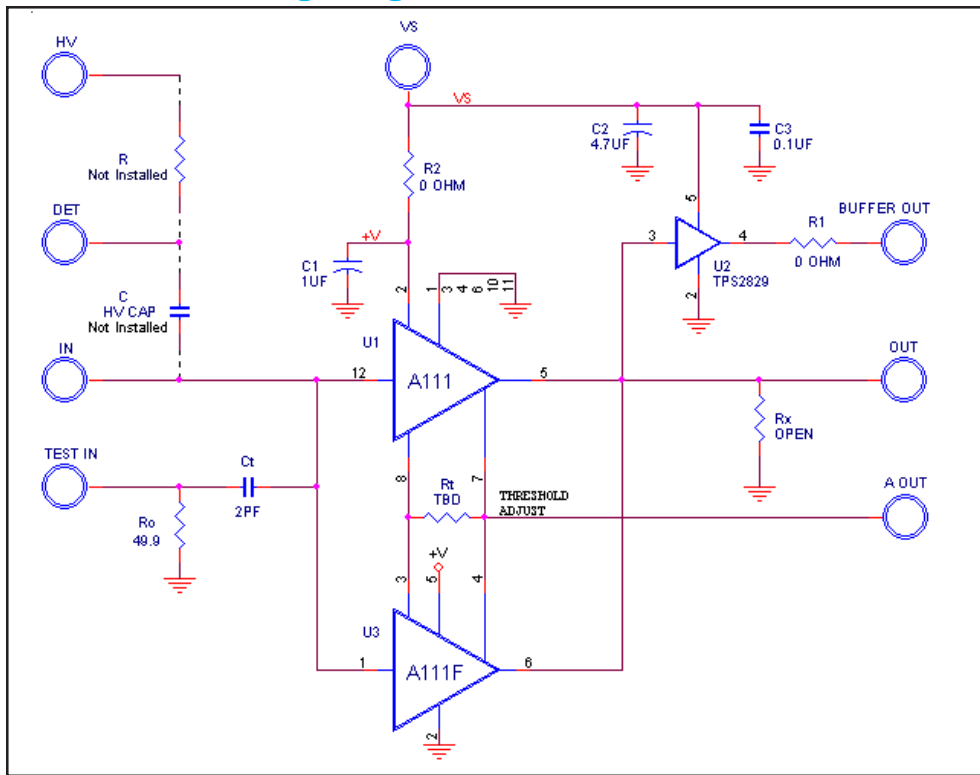

The A111 or A111F can be tested with a pulser by using the small 2 pF test capacitor to inject a test charge into the input. The unit will trigger on the negative-going edge of the test pulse, which should have a transition time of less than 20 ns. This negative going edge should be followed by a relatively flat part of the waveform so that it appears as a step function. For example, a square wave is a good test waveform. When using a square wave, it should be noted that the unit will respond to the positive-going edge also, at amplitudes above 2x threshold. Alternately, a “sawtooth” waveform or a tail pulse with long fall time (>1 μs) may be used.

Typical test circuit

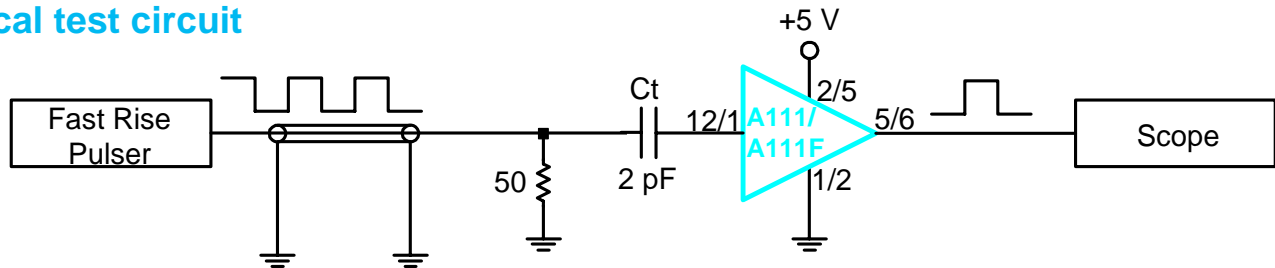

T_{rise}: < 20 ns (negative-going edge)

Amplitude: 500 mV/picocoulomb; 4 mV at the nominal threshold.

Charge transfer to the input is according to $Q = C_t V$, where Q = total charge, C_t = value of test capacitor, and V = amplitude of voltage step. Use only the TEST INPUT to test the A111/A111F with a pulser. DO NOT connect the test pulser to the input directly or through a large capacitor (>100 pF) as this can produce a large current in the input transistor and cause irreversible damage.

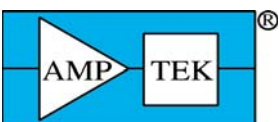

Amptek Inc. 14 DeAngelo Drive, Bedford, MA 01730-2204 USA

Tel: +1 781 275-2242 Fax: +1 781 275-3470 Email: sales@amptek.com <http://www.amptek.com>