

ELECTRON AND ION DETECTOR FOR ULTRA-HIGH VACUUM

MD-502

A complete CEM detector system for ultra-high vacuum use

ULTRA-HIGH VACUUM PACKAGED CEM FEATURES:

- Ceramic channel electron multiplier
- Stainless steel faraday housing
- Bakeable to +300 °C
- Operational from cryogenic to +200 °C
- Ceramic and gold UHV connector



REMOTE ELECTRONIC SYSTEM FEATURES:

- Low voltage supply (AC/DC converter)
- High voltage supply
- Charge sensitive preamplifier & discriminator
- Test pulse
- Line driver

The **AMPTEKTRON MD-502** is a compact, easy to use electron multiplier system capable of detecting electrons, ions, vacuum ultra-violet, soft x-rays, and other nuclear particles at rates greater than 10^6 events per second. It is configured in a pulse counting mode and operates from a single low voltage supply.

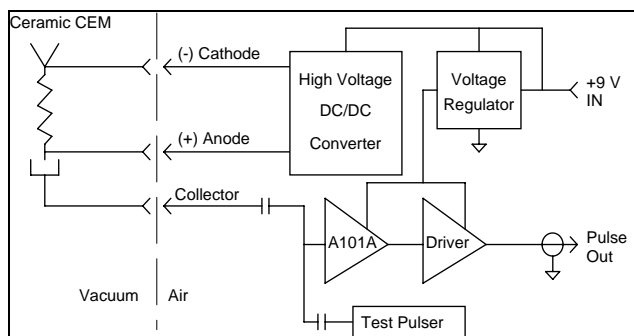

The **AMPTEKTRON MD-502** is designed for direct applications in the field of mass spectrometer, laboratory and research experiments, vacuum process monitoring and beam diagnosis, particularly in systems requiring ultra-high vacuum operation. It requires three high voltage connections to the UHV CEM.

The aperture (A) is normally 3.6 mm diameter, which can be increased up to 10 mm diameter.

Block Diagram

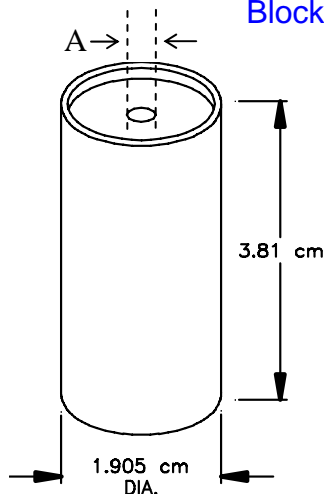

MD-502 CEM Housing

	Ion mode	Electron mode
Cathode	-2400 VDC	+500 VDC
Anode	Ground	+2900 VDC
Collector	Virtual ground	+2900 VDC

The three CEM electrical connections are supplied via SHV connectors on the MD-502 electronics box. The CEM contains a self-biasing resistive strip that creates a +100 VDC potential between the output of the CEM charge cloud and the collector. This ensures efficient collection of the charge cloud output. The voltage of the bias potentials depends upon the mode selected for the MD-502. The cathode potential appears on the CEM cone and serves as a rejection potential for deselected species and an acceleration field for the selected species. Thus, thermal ions will be strongly attracted to the -2400 VDC in the ion mode, but will be repelled by the +500 volts encountered in electron mode. Electrons experience the opposite effects, being attracted by the +500 volts and strongly repelled by the -2400 volts in the ion mode. Particles with energies in excess to these rejection fields will be able to penetrate and be counted.

Refer also to specifications for MD-501.