

Charge Sensitive Preamplifier-Discriminator

A111



Features

- Small size (TO-8 package) allows mounting close to detector.
- Power required is typically 6 mW.
- Single power supply voltage.
- Output interface directly with CMOS and TTL logic.
- Input threshold is externally adjustable.
- Analog monitor point.
- High reliability process.
- 6 Pin SIP available as model A111F.
- One year warranty.

Applications

- Mass spectrometers
- Particle detection
- Imaging
- Laboratory experiments
- Research experiments
- Portable instrumentation
- Aerospace
- Medical electronics
- Electro-optical systems

Overview

Model A111 is a hybrid charge sensitive preamplifier, discriminator, and pulse shaper developed especially for instrumentation employing microchannel plates (MCP), channel electron multipliers (CEM), photomultipliers, proportional counters and other low capacitance charge producing detectors in the pulse counting mode.

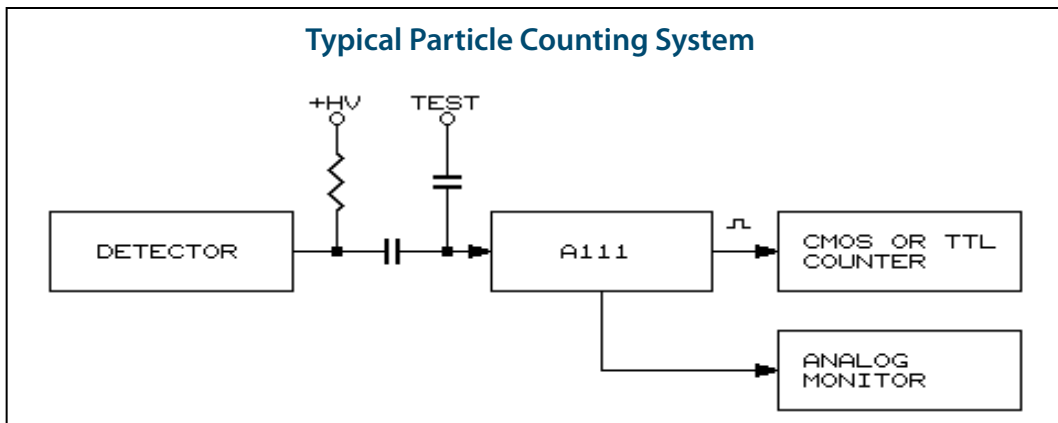

A111 Specifications

Test Conditions: ($V_S = +5\text{ V}$, $T = +25\text{ }^\circ\text{C}$)

INPUT CHARACTERISTICS	
Threshold	Model A111 has a nominal threshold referred to the input of 8×10^{-15} coulomb. This is equivalent to 5×10^4 electrons. The threshold can be increased by the addition of a resistor between Pins 7 and 8. Shorting these Pins together produces the maximum increase (approximately 10x). See Figure 1.
Stability	+5%, -2% of +25 °C threshold, 0 to +50 °C.
Supply voltage	Threshold supply voltage coefficient: -0.8% / V typical
Noise (typical)	4.4×10^{-16} coulombs RMS; 5.5% of nominal threshold
Noise Slope (typical)	9×10^{-17} coulombs RMS/pF
Detector Capacitance	0 to 250 pF
Protection	300 Ω resistor in series with input followed by back-to-back diodes to ground

OUTPUT CHARACTERISTICS	
Pin 5 provides a positive output pulse capable of interfacing directly with CMOS and other logic. See Operating Notes.	
Pin 7 provides a positive analog pulse output from the preamplifier section just prior to the discriminator with a rise time of about 100 ns. At maximum sensitivity (no feedback resistor between Pins 7 and 8) the amplitude of this pulse is proportional to the input charge, $A = 2.5\text{ V/pC}$. At threshold this will correspond to a 20 mV pulse. If a feedback resistor is used between Pins 7 and 8, the size of the analog pulse will be divided by the same threshold attenuation factor the feedback resistor produced. Example: If a 3 k Ω feedback resistor is used, the size of the analog pulse will be 1 V/pC. This output must be capacitively coupled to external circuitry and can be used to perform pulse height analysis. Near threshold, however, the shape of the analog pulse will be effected by the firing of the discriminator.	

Pulse Characteristics	
Risetime	25 ns
Falltime	220 ns with $C_{LOAD} = 5\text{ pF}$; 90 ns with $C_{LOAD} = 5\text{ pF}$ and $R_{LOAD} = 2\text{ k}\Omega$
Width	260 ns at threshold, 310 ns at 10x threshold, with $C_{LOAD} = 5\text{ pF}$
Amplitude	4.7 V (approximately 95% of V_S)
Protection	Diodes to ground and V_S

GENERAL	
Count Rate	2.5×10^6 CPS periodic
Pulse Pair Resolution	1) Normal: 350 ns; two identical 10x threshold pulses. 2) Overload: 800 ns; 100x threshold followed by 10x threshold.
Operating Voltage	+4 to +10 VDC

Operating Current (typical)	1.3 mA quiescent. 1.4 mA @ 10^5 CPS. 1.9 mA @ 10^6 CPS Operating current is essentially independent of V_S .
Temperature	-55 to +85 °C operational
Package	12 Pin, TO-8 case. (6 Pin SIP available as A111F)
Weight	2.5 g
Screening	Amptek High Reliability
Warranty	One year
Test Board	PC-21

Vacuum
Due to its hermetic seal and small size, the A111 is well suited to use within a vacuum chamber. In such applications care should be taken to avoid electrical discharge near the input which can damage the unit and VOID WARRANTY

Use care in soldering leads - avoid overheating.

Pin Configuration (14 pin hybrid DIP)	
Pins 1, 3, 4, 6, 10, 11	Ground and case
Pin 2	V_S (+4 to +10 VDC)
Pin 5	Output
Pin 7	Analog monitor
Pins 7,8	Threshold adjustment
Pin 9	No connection
Pin 12	Input

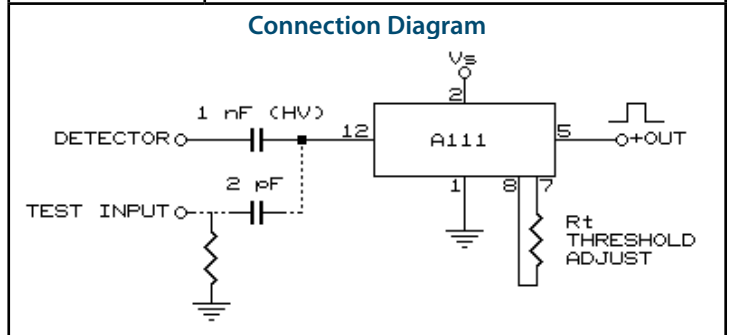

Typical Waveforms @ 25x Threshold

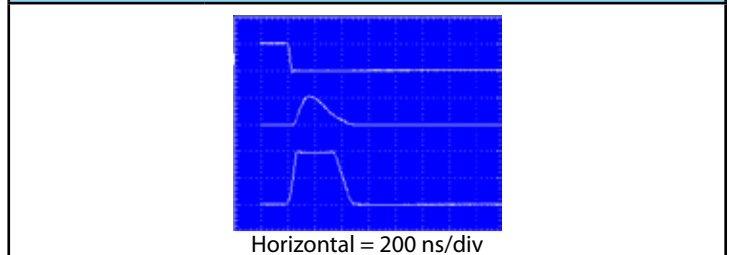

Top trace	Input test pulse through 2 pF capacitor. The A111 responds during the risetime of the test pulse. Vertical scale: 100 mV/div.
Middle trace	Analog pulse, Pin 7. Vertical scale: 0.5 V/div.
Bottom trace	Discriminator output, Pin 5, driving a 1 k Ω load at $V_S = +5\text{ V}$. Vertical scale: 2 V/div.

A111 Operating Notes

Circuit Layout

Due to the high sensitivity of the A111, care should be taken in circuit layout. In general, ground plane construction is recommended, with all ground Pins (1,3,4,6,10,11, and 9) connected to this plane. Input and output lines should be kept well separated and in most cases shielding will be necessary. Particular attention should be paid to the detector ground connection to avoid multiple pulsing and oscillation due to feedback. The supply voltage is internally decoupled which prevents the A111 from responding to supply line transients of up to 100 mV amplitude. While this is normally adequate, in some applications external bypassing (typically 10 nF) may be helpful. The PC21 may be used as an example of appropriate layout techniques.

Power Supply

While specifications are given for operation at +5 V, the characteristics of the A111 are relatively unaffected by changes in supply voltage from 4 to 10V. Parameters critical to a particular application should be checked at the actual operating voltage.

Input

The A111 has an internal input protection network, including a coupling capacitor, as shown in the diagram below. However, it is not possible to fully protect against high voltage discharge through the input.

Example:

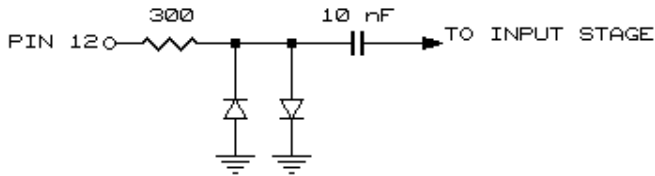

Two precautions should be kept in mind:

1. The detector anode should normally be capacitively coupled to Pin 12 with a capacitor of adequate voltage rating such that it cannot break down under operating conditions. In some applications, where the detector cathode is operated at negative potential, the anode can be directly connected to Pin 12.
2. When the detector bias is turned on, the rise of high voltage at the detector should be slow enough to prevent large transient currents through the coupling capacitor into the input. This is normally provided for by a high voltage RC Filtering network with components of adequate voltage rating.

In general, it is important to avoid high voltage discharge in any part of the circuit.

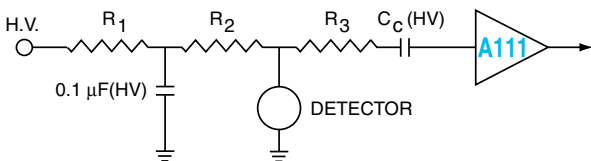

Where typically $R_1, R_2 > 1 \text{ M}$. R_3 optional additional protection to limit input current, usually less than 1 k.

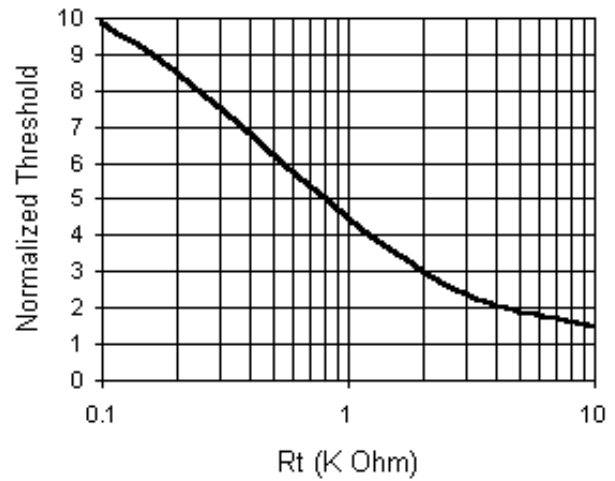

Figure 1: Threshold vs. R_T

The A111 will respond to a negative pulse of 8×10^{-15} coulombs or greater. The threshold may be increased by the connection of a resistor between Pins 7 and 8. Approximate values are given in Figure 1.

While this device is optimized for negative input pulses, it will respond to positive input pulses greater than approximately 2x the negative threshold. Because the specifications provided herein apply to negative input, the user should measure all relevant operating characteristics for any positive-input applications.

The A111 can be tested with a pulser by using a small capacitor (usually 1 or 2 pF) to inject a test charge into the input. The unit will trigger on the negative-going edge of the test pulse, which should have a transition time of less than 20 ns. This negative going edge should be followed by a relatively flat part of the waveform so that it appears as a step function. For example, a square wave is a good test waveform. (When using a square wave, it should be noted that the unit will respond to the positive-going edge also, at amplitudes above 2x threshold.) Alternately, a "sawtooth" waveform or a tail pulse with long fall time ($> 1 \mu\text{s}$) may be used.

Typical Test Circuit

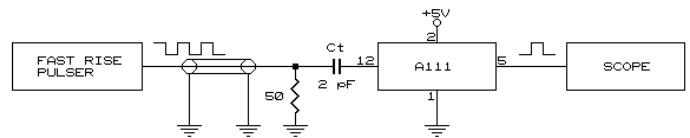

$T_{\text{rise}} < 20 \text{ ns}$ (negative-going edge)
Amplitude: 500 mV/picocoulomb; 4 mV at the nominal threshold.

Charge transfer to the input is according to $Q = C_t \cdot V$, where Q = total charge, C_t = value of test capacitor, and V = amplitude of voltage step. DO NOT connect the test pulser to the input directly or through a large capacitor ($> 100 \text{ pF}$) as this can produce a large current in the input transistor and cause irreversible damage.

A111 Operating Notes (con't)

Output

The output circuit of the A111 is a PNP transistor with a 6 kΩ collector load to ground:

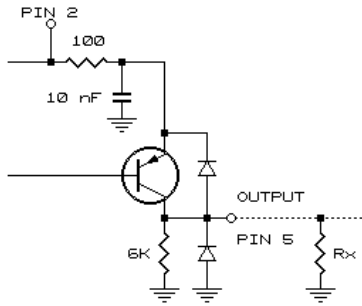

This circuit directly drives CMOS inputs with wide voltage swing and thus excellent noise immunity. The high value (6 kΩ) load resistor minimizes both internal ground currents and power consumption in critical applications. In applications where load capacitance is significant and high count rate performance is important, the addition of an external resistor Rx from Pin 5 to ground will shorten the fall time of the output pulse. A typical value for load capacitance of 10 to 50 pF, is 2 kΩ. At the expense of pulse amplitude, low impedance circuits may be driven, e.g. terminated coaxial cable. For example, terminated 50 Ω cable can be driven with a pulse amplitude of 1.4 V ($V_s = 5$ V).

To interface the A111 directly with TTL, a value for Rx must be chosen to sink the required low level input current of the TTL device. For example, for low power devices requiring $I_{in} = 0.4$ mA at 0.4 V, the maximum value for Rx in parallel with the 6 kΩ is 1 kΩ. For devices requiring more than 2 mA current sinking, an inverting NPN transistor interface between the A111 and the input is recommended.

Additional Threshold Adjustment

A) Increasing the Threshold of the A111:

Increasing the threshold of the A111 beyond the 10x provided by shorting out Pins 7 and 8 can be achieved by an RC feedback as shown.

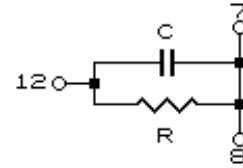

Apart from unit to unit variation, the discrimination levels will be as follows:

- Shorting out Pins 7 and 8 will result in 10x increase of nominal threshold: $(5 \times 10^4 \text{ electrons}) \times 10 = 5 \times 10^5 \text{ electrons}$.
- Shorting out Pins 7 and 8 plus feedback:

R = 50 k	C = 2.2 pF	: 17x
R = 20 k	C = 3.3 pF	: 23x
R = 5 k	C = 4.7 pF	: 40x
R = 2 k	C = 6.8 pF	: 88x

Intermediate values can be obtained by adjusting the value of R.

B) Decreasing the Threshold of the A111:

Decreasing the threshold of the A111 beyond the nominal 5×10^4 electrons can be achieved by adding a resistor from Pin 8 to ground. A 300 Ω resistor will approximately double the sensitivity resulting in a threshold of 2.5×10^4 electrons.

Mechanical Dimensions

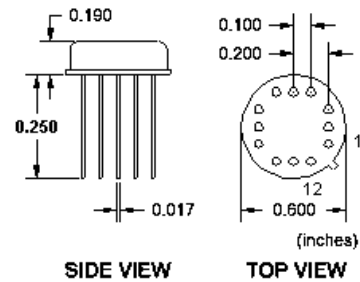

Line Driver for A111

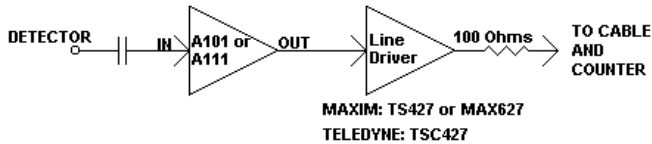

Applications

A Microchannel Plate (MCP) Array Connected to Multiple A111s

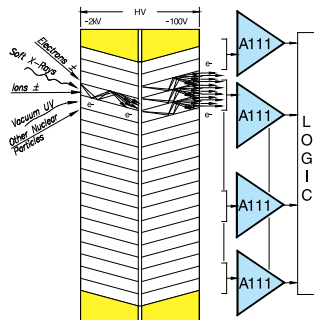

Connection of a Photomultiplier Tube to the A111

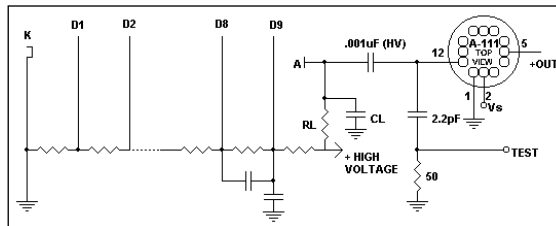

Connection of a Channel Electron Multiplier to the A111

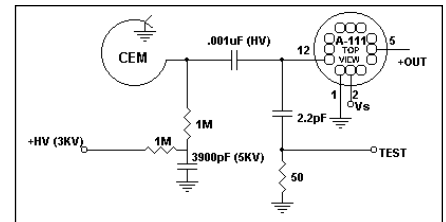

CAUTION for the A111

The A111 incorporates an input protection network (see specifications). However, it is not possible to fully protect against high voltage discharge through the input.

Two precautions should be kept in mind:

- 1) The high voltage coupling capacitor should be of sufficient voltage rating that it cannot break down under operating conditions.
- 2) When detector bias is turned on, the rise of high voltage at the detector should be slow enough to prevent large transient currents through the coupling capacitor into the input. This is normally provided for by a high voltage RC Filtering network with components of adequate voltage rating.

In general, it is important to avoid high voltage discharge in any part of the circuit.

EXAMPLE:

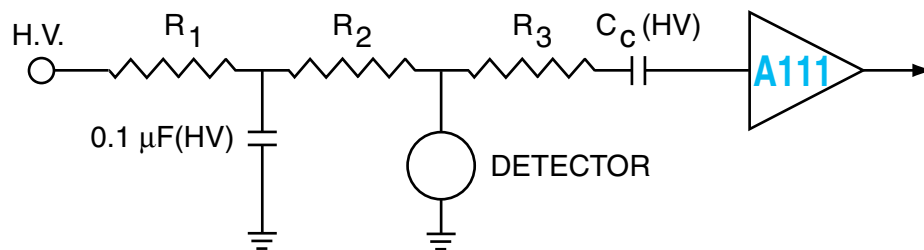

Where typically $R_1, R_2 > 1 \text{ M}$

R_3 optional additional protection to limit input current, usually less than 1 K

PC21 Test Board for the A111 and A111F

The PC21 is a printed circuit board designed to facilitate testing of the A111 or the A111F. In addition to testing circuitry, it provides component locations for use with detectors. Ground plane construction minimizes external pick-up.

INPUTS	
IN	Detector Input; A111/Pin 12; A111F/Pin 1. Should be AC coupled with a high voltage capacitor (500 pF - 1000 pF).
DET	Provides post to connect the detector and input capacitor
TEST IN	Input to test circuit as described in specifications
Vs	A111/Pin 2; A111F/Pin 5; supply voltage (+4 to +10 VDC); supply voltage (+4 to +10 VDC)
H.V.	Provides post to connect the detector to the high voltage supply through a resistor
OUTPUTS	
OUT	Positive, TTL type output from A111/Pin 5; A111F/Pin 6
A OUT	Positive, Analog output from A111/PIN 7; A111F/PIN 4
BUF OUT	Positive output through a Buffer/Line Driver IC from A111/ PIN 5; A111F/PIN 6.
COMPONENTS	
C ₁ , C ₂ , C ₃	Filter capacitor (1 μF, 4.7 μF, 0.1 μF)
C _T	Test capacitor (2 pF)
R _O	Test pulse termination (50 Ω)
R _X	External load resistor (see specifications)
R _T	Threshold adjust resistor
R	Detector bias resistor (user supplied)
C	Detector coupling capacitor (HV) (user supplied)
U ₂	Line Driver TPS2829

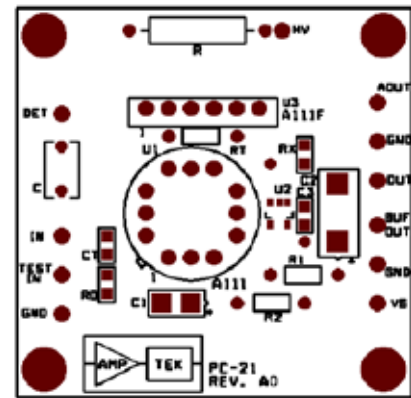

Dimensions: 1.75 x 1.75 x 1.0 in
4.45 x 4.45 x 2.54 cm

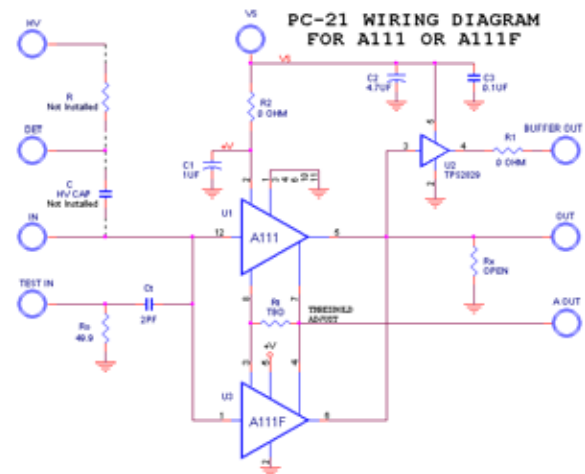

The A-111 or A111F can be tested with a pulser by using a small 2 pF capacitor to inject a test charge into the input. The unit will trigger on the negative-going edge of the test pulse, which should have a transition time of less than 20 ns. This negative going edge should be followed by a relatively flat part of the waveform so that it appears as a step function. For example, a square wave is a good test waveform. When using a square wave, it should be noted that the unit will respond to the positive-going edge also, at amplitudes above 2x threshold. Alternately, a "sawtooth" waveform or a tail pulse with long fall time (>1 μs) may be used.

Typical Test Circuit

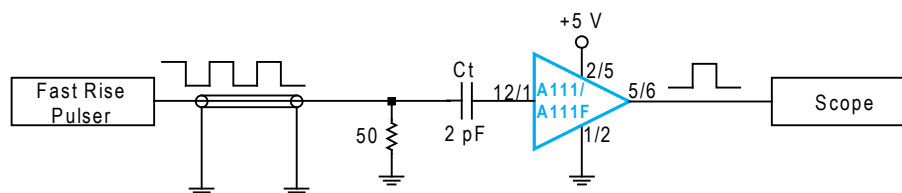

T_{rise}: <20 ns (negative-going edge).

Amplitude: 500 mV/picocoulomb; 4 mV at the nominal threshold.

Charge transfer to the input is according to $Q = C_t V$, where Q = total charge, C_t = value of test capacitor, and V = amplitude of voltage step. Use only the TEST INPUT to test the A111/A111F. DO NOT connect the test pulser to the input directly or through a large capacitor (>100 pF) as this can produce a large current in the input transistor and cause irreversible damage.

For more information, please see <http://www.amptek.com>

AMPTEK INC.

14 DeAngelo Drive, Bedford, MA 01730-2204 U.S.A.

+1 781 275-2242 Fax: +1 781 275-3470 sales@amptek.com **www.amptek.com**

